

**SURVEYOR'S CERTIFICATE**

I, KYLE W. LATIMER, BEING A REGISTERED PROFESSIONAL LAND SURVEYOR IN THE STATE OF OREGON CERTIFY THAT I HAVE CORRECTLY SURVEYED AND MARKED WITH PROPER MONUMENTS THE LANDS REPRESENTED HEREON PER ORS 92, THE EXTERIOR BOUNDARY OF WHICH IS DESCRIBED AS FOLLOWS:

BEGINNING AT A CARRIAGE BOLT WITH WASHER SET IN CONCRETE WHICH IS THE SOUTHEAST CORNER OF LOT 10, BLOCK 10 OF THE COLLEGE HILL ADDITION IN THE NORTHEAST 1/4 OF SECTION 34 OF TOWNSHIP 11 SOUTH, RANGE 5 WEST OF THE WILLAMETTE MERIDIAN; THENCE NORTH 83°02'51" WEST 137.91 FEET TO A 5/8" IRON ROD OF UNKNOWN ORIGIN ON THE CURRENT RIGHT-OF-WAY OF NW 23RD STREET; THENCE NORTH 00°53'43" WEST 53.92 FEET ALONG SAID RIGHT-OF-WAY TO A 5/8" IRON ROD; THENCE SOUTH 83°45'06" EAST 137.70 FEET TO A 5/8" IRON ROD SET ON THE ALLEY RIGHT-OF-WAY; THENCE SOUTH 00°52'46" EAST 55.63 FEET ALONG SAID RIGHT-OF-WAY TO THE POINT OF BEGINNING.  
 \* 137.70 55.63  
 ABOVE DESCRIBED AREA CONTAINING 7483 SQUARE FEET.

**NARRATIVE:**

THE PURPOSE OF THIS SURVEY WAS TO PARTITION THE LAND DESCRIBED IN BENTON COUNTY DEED DOCUMENT NO. 2019-582516, DESCRIBED THEREIN AS LOT 10 AND THE SOUTH 2 FEET OF BLOCK 9 OF BLOCK 10 OF THE SUPPLEMENTARY PLAT OF THE COLLEGE HILL ADDITION TO CORVALLIS, PER CITY OF CORVALLIS CASE PAR 2023-02.

THE BOUNDARY OF LOT 10 AND SOUTHERLY 2' OF LOT 9, BLOCK 10 OF THE COLLEGE HILL ADDITION WAS SURVEYED IN CS. 8953, AFTER THE INITIAL SUBDIVISION WAS RECORDED. IN THAT SURVEY, ALL CORNERS OF THE SUBJECT PROPERTY WERE SET. THE EASTERLY MONUMENTS OF SAID SURVEY WERE RECOVERED IN THIS PLAT AND HELD. A 5/8" IRON ROD WAS RECOVERED ON THE SOUTHWEST CORNER OF LOT 10 WHICH DOES NOT MATCH THE DESCRIPTION OF THE MONUMENT FOUND IN C.S. 8953. DESPITE THE MONUMENT TYPE NOT MATCHING, THE LOCATION WAS HELD FOR THE ORIGINAL CORNER OF LOT 10. THE ORIGINAL NORTHWEST CORNER OF LOT 10 WAS ESTABLISHED BY HOLDING RECORD DISTANCE FROM THE SOUTHWEST CORNER AND THE RIGHT-OF-WAY FOR N.W. 23 STREET. THE RIGHT-OF-WAY WAS RETRACED BY HOLDING THE SOUTHWEST CORNER OF LOT 10 AND THE 5/8" IRON ROD THAT IS THE NORTH-NORTHWEST CORNER OF PARCEL 1 OF PARTITION PLAT 2008-033 AND HOLDING A 10' OFFSET TO ESTABLISH THE ORIGINAL RIGHT OF WAY (40').

**OWNER'S DECLARATION:**

KNOW ALL PERSONS THAT MOISES C. MORENO, AS TO AN UNDIVIDED 50% INTEREST, AND ELAINE S. MORENO, AS TO AN UNDIVIDED 50% INTEREST, AS TENANTS IN COMMON ARE THE OWNERS OF THE LAND DESCRIBED HEREON AND HEREBY GRANT A PUBLIC UTILITY EASEMENT, AS SHOWN, WE HEREBY DEDICATE FIVE FEET OF ADDITIONAL RIGHT OF WAY FOR PUBLIC USE WITHOUT ANY RESERVATION WHATSOEVER.

*Moises C. Moreno*  
 MOISES C. MORENO  
*Elaine S. Moreno*  
 ELAINE S. MORENO

**ACKNOWLEDGMENT:**

STATE OF OR )  
 COUNTY OF Linn ) SS  
 THIS IS TO CERTIFY THAT ON THIS 20 DAY OF March, 2024, BEFORE ME A NOTARY PUBLIC IN AND FOR SAID COUNTY AND STATE, PERSONALLY APPEARED MOISES C. MORENO AND ELAINE S. MORENO NAMED IN ABOVE CAPACITY AND WHO EXECUTED THE FOREGOING DECLARATION AND ACKNOWLEDGED TO ME THAT THEY EXECUTED THE SAME FREELY AND VOLUNTARILY FOR THE USES AND PURPOSES HEREIN NAMED.

*Amanda Albert*  
 NOTARY SIGNATURE  
*Amanda Albert*  
 NOTARY PUBLIC - OREGON  
 (PRINT NAME)

COMMISSION NO. 1004109  
 MY COMMISSION EXPIRES September 20, 2024

**APPROVALS:**

CITY OF CORVALLIS CASE PAR-2023-02:  
 WE THE UNDERSIGNED HAVE EXAMINED AND APPROVED THE PORTION OF THIS PLAT AS REQUIRED BY THE DESIGNATED AUTHORITY OF OUR RESPECTIVE OFFICES.

*Ja. M...* 4/2/24  
 BENTON COUNTY SURVEYOR DATE  
*[Signature]* 3/26/24  
 CORVALLIS PLANNING DIVISION MANAGER DATE  
*J. J. ...* 3/26/24  
 CORVALLIS CITY ENGINEER DATE

**RECORDER'S STATEMENT:**

STATE OF OREGON )  
 COUNTY OF BENTON ) SS  
 I HEREBY CERTIFY THAT THE PARTITION PLAT WAS RECEIVED AND DULY RECORDED BY ME AS PARTITION PLAT 2024 - 004 IN BENTON COUNTY RECORDS DOCUMENT NO. 2024 - 104337, ON THIS 2nd DAY OF Apr., 2024, AT 2:03 O'CLOCK pm  
 FOR !!!  
 BENTON COUNTY CLERK

**ASSESSOR'S STATEMENT:**

ALL TAXES, FEES, ASSESSMENTS AND OTHER CHARGES AS PROVIDED BY ORS 92.095 HAVE BEEN PAID THROUGH June 30, 2024.  
*For [Signature]* 4/2/2024  
 DIRECTOR, BENTON COUNTY DEPARTMENT OF ASSESSMENT DATE

*[Signature]* 04/02/2024  
 BENTON COUNTY TAX COLLECTOR DATE

**EASEMENTS OF RECORD:**

A TITLE REPORT PREPARED BY AMERITITLE ORDER NO. 623943AM REVEALED THE FOLLOWING EASEMENTS OF RECORD:  
 NO EASEMENTS OF RECORD WERE FOUND AT THIS TIME.  
 AFFIDAVIT OF CONSENT BY CITIZENS BANK RECORDED IN BENTON COUNTY  
 DEED RECORDS PER DOCUMENT NO. 2024 - 643377

I HEREBY CERTIFY THIS TO BE A TRUE AND EXACT COPY OF THE ORIGINAL PLAT.  
*Kyle W. Latimer*  
 KYLE W. LATIMER

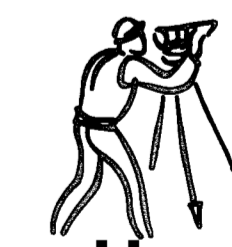

REGISTERED PROFESSIONAL LAND SURVEYOR  
 OREGON  
 JUNE 12, 2013  
 KYLE W. LATIMER  
 #80442  
 EXPIRES 12-31-2024  
 SHEET 1 OF 1

**Udell ENGINEERING & LAND SURVEYING, LLC**  
 63 EAST ASH ST. LEBANON, OREGON 97355  
 PH. (541) 451-5125  
 FAX (541) 451-1366  
 22-211 MORENO

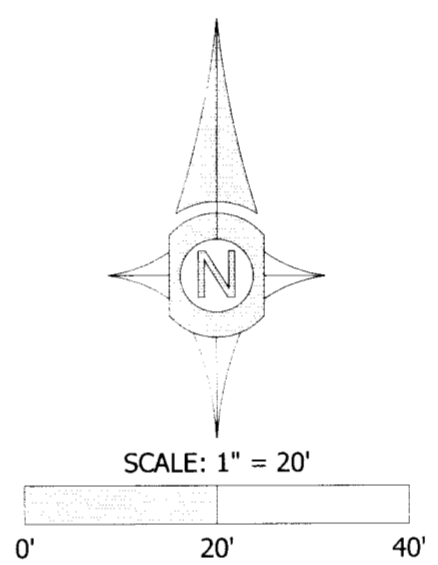

**LEGEND**

- FOUND MONUMENT AS NOTED
  - SET 5/8"x30" IRON ROD WITH ORANGE PLASTIC CAP STAMPED: UDELL ENG
  - ( ) DATA OF RECORD PER AS NOTED
  - [ ] CALCULATED DATA
  - CS COUNTY SURVEY
  - FD FOUND
  - IR IRON ROD
  - IP IRON PIPE
  - R/W RIGHT OF WAY
  - W/ WITH
- REFERENCE SURVEYS: C.S. 8953

PARTITION PLAT NO. 2024004  
 MOISES C. AND ELAINE S. MORENO  
 A REPLAT OF  
 LOT 10 & A PORTION OF LOT 9, BLOCK 10,  
 SUPPLEMENTAL PLAT OF THE  
 COLLEGE HILL SUBDIVISION  
 IN THE  
 NE 1/4 SEC. 34, T. 11 S., R. 5 W., W.M.  
 BENTON COUNTY, OREGON  
 FEBRUARY 12, 2024  
 CITY OF CORVALLIS CASE PAR-2023-02

